



Semitronics Corp., 64 Commercial St. Freeport, NY 11520 Tel. (516) 623-9400 FAX (516) 623-6954

Power Thyristor 2500 Amps - 2600 Volts TN450CH series

Features:

- . All Diffused Structure
- . Amplifying Gate Configuration
- . Blocking Capability to 2600 V
- . Guaranteed Maximum Turn-Off Time
- . High dV/dt Capability
- . Pressure Assembled Device

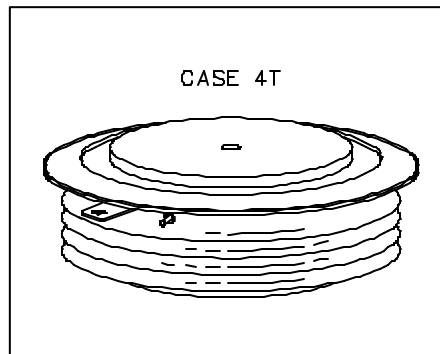

ELECTRICAL CHARACTERISTICS AND RATINGS

Blocking - Off State

Device Type	V _{RRM} (1)	V _{DRM} (1)	V _{RSM} (1)
TN450CH16	1600	1600	1700
TN450CH18	1800	1800	1900
TN450CH20	2000	2000	2100
TN450CH22	2200	2200	2300
TN450CH24	2400	2400	2500
TN450CH26	2600	2600	2700

V_{RRM} = Repetitive peak reverse voltage

V_{DRM} = Repetitive peak off state voltage

V_{RSM} = Non repetitive peak reverse voltage (2)

Repetitive peak reverse leakage and off state leakage	I _{RRM} / I _{DRM}	15 mA 65 mA (3)
Critical rate of voltage rise	dV/dt (4)	1000 V/μsec

Notes:

All ratings are specified for T_j=25 °C unless otherwise stated.

- (1) All voltage ratings are specified for an applied 50Hz/60Hz sinusoidal waveform over the temperature range -40 to +125 °C.
- (2) 10 msec. max. pulse width
- (3) Maximum value for T_j = 125 °C.
- (4) Minimum value for linear and exponential waveshape to 80% rated V_{DRM}. Gate open. T_j = 125 °C.
- (5) Non-repetitive value.
- (6) The value of di/dt is established in accordance with EIA/NIMA Standard RS-397, Section 5-2-2-6. The value defined would be in addition to that obtained from a snubber circuit, comprising a 0.2 μF capacitor and 20 ohms resistor in parallel with the thristor under test.

Conducting - on state

Parameter	Symbol	Min.	Max.	Typ.	Units	Conditions
Average value of on-state current	I _{T(AV)}		1300		A	Sinewave, 180° conduction, T _c =65°C
RMS value of on-state current	I _{TRMS}		2560		A	Nominal value
Peak one cPSTCle surge (non repetitive) current	I _{TSM}		20000 18000		A A	8.3 msec (60Hz), sinusoidal wave-shape, 180° conduction, T _j = 125 °C 10.0 msec (50Hz), sinusoidal wave-shape, 180° conduction, T _j = 125 °C
I square t	I ² t		1.8x10 ⁶		A ² s	8.3 msec and 10.0 msec
Latching current	I _L		800		mA	V _D = 24 V; R _L = 12 ohms
Holding current	I _H		400		mA	V _D = 24 V; I = 2.5 A
Peak on-state voltage	V _{TM}		1.75		V	I _{TM} = 3000 A; Duty cPSTCle ≤ 0.01%
Critical rate of rise of on-state current (5, 6)	di/dt		600		A/μs	Switching from V _{DRM} ≤ 1000 V, non-repetitive
Critical rate of rise of on-state current (6)	di/dt		300		A/μs	Switching from V _{DRM} ≤ 1000 V

TN450CH series Power Thyristor

Page 2 of 4

ELECTRICAL CHARACTERISTICS AND RATINGS (cont'd)

Gating

Parameter	Symbol	Min.	Max.	Typ.	Units	Conditions
Peak gate power dissipation	P_{GM}		200		W	$t_p = 40 \mu s$
Average gate power dissipation	$P_{G(AV)}$		5		W	
Peak gate current	I_{GM}		10		A	
Gate current required to trigger all units	I_{GT}		300 150 125		mA mA mA	$V_D = 6 V; R_L = 3 \text{ ohms}; T_j = -40^\circ C$ $V_D = 6 V; R_L = 3 \text{ ohms}; T_j = +25^\circ C$ $V_D = 6 V; R_L = 3 \text{ ohms}; T_j = +125^\circ C$
Gate voltage required to trigger all units	V_{GT}	0.30	5 3		V V V	$V_D = 6 V; R_L = 3 \text{ ohms}; T_j = -40^\circ C$ $V_D = 6 V; R_L = 3 \text{ ohms}; T_j = 0-125^\circ C$ $V_D = \text{Rated } V_{DRM}; R_L = 1000 \text{ ohms}; T_j = +125^\circ C$
Peak negative voltage	V_{GRM}		5		V	

Dynamic

Parameter	Symbol	Min.	Max.	Typ.	Units	Conditions
Delay time	t_d		1.5	0.7	μs	$I_{TM} = 50 A; V_D = \text{Rated } V_{DRM}$ Gate pulse: $V_G = 20 V; R_G = 20 \text{ ohms}; t_r = 0.1 \mu s; t_p = 20 \mu s$
Turn-off time (with $V_R = -50 V$)	t_q		250	150	μs	$I_{TM} = 1000 A; di/dt = 25 A/\mu s;$ $V_R \geq -50 V; \text{Re-applied } dV/dt = 20 V/\mu s$ linear to 80% $V_{DRM}; V_G = 0;$ $T_j = 125^\circ C; \text{Duty cPSTC} \geq 0.01\%$
Reverse recovery charge	Q_{rr}		*		μC	$I_{TM} = 1000 A; di/dt = 25 A/\mu s;$ $V_R \geq -50 V$

* For guaranteed max. value, contact factory.

THERMAL AND MECHANICAL CHARACTERISTICS AND RATINGS

Parameter	Symbol	Min.	Max.	Typ.	Units	Conditions
Operating temperature	T_j	-40	+125		$^\circ C$	
Storage temperature	T_{stg}	-40	+150		$^\circ C$	
Thermal resistance - junction to case	$R_{\Theta(j-c)}$		0.025 0.050		$^\circ C/W$	Double sided cooled Single sided cooled
Thermal resistance - case to sink	$R_{\Theta(c-s)}$		0.010 0.020		$^\circ C/W$	Double sided cooled * Single sided cooled *
Mounting force	P	5500 24.5	6000 26.7		lb. kN	
Weight	W			16 460	oz. g	

* Mounting surfaces smooth, flat and greased

TN450CH series Power Thyristor

ELECTRICAL CHARACTERISTICS AND RATINGS (cont'd)

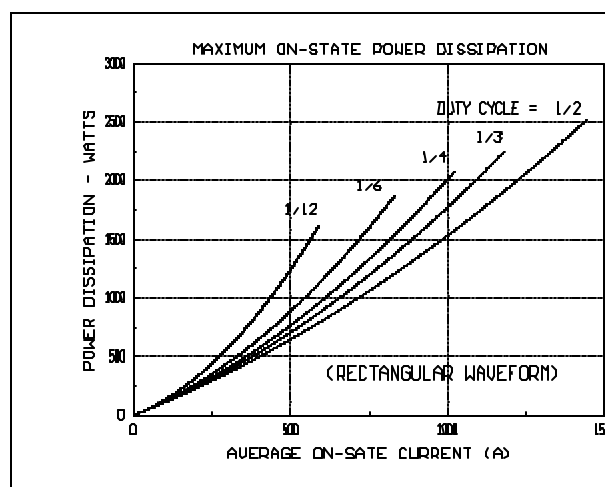
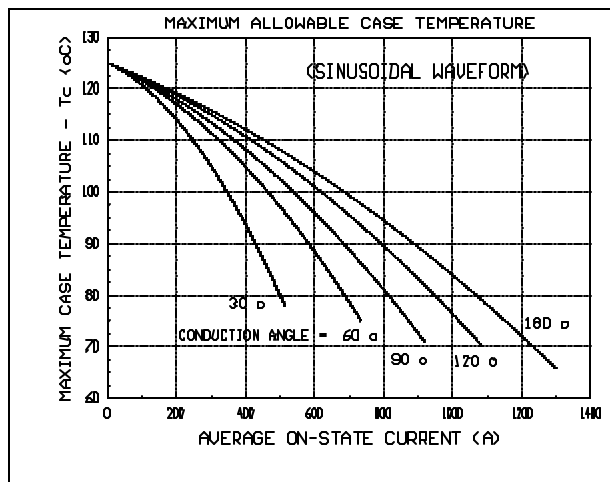
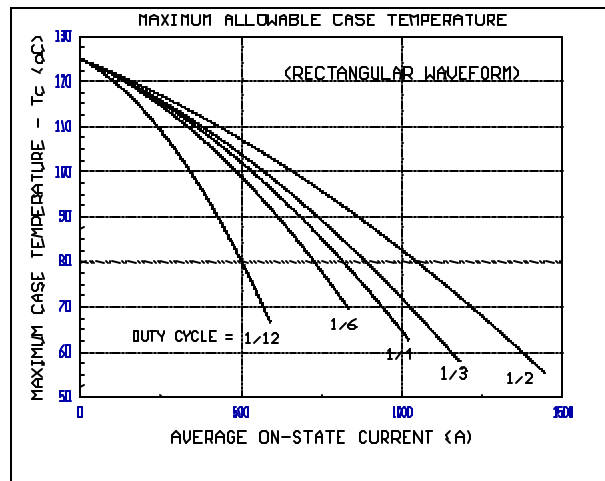
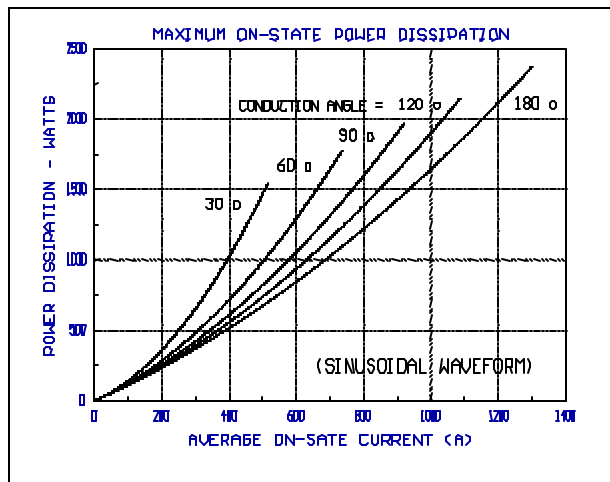
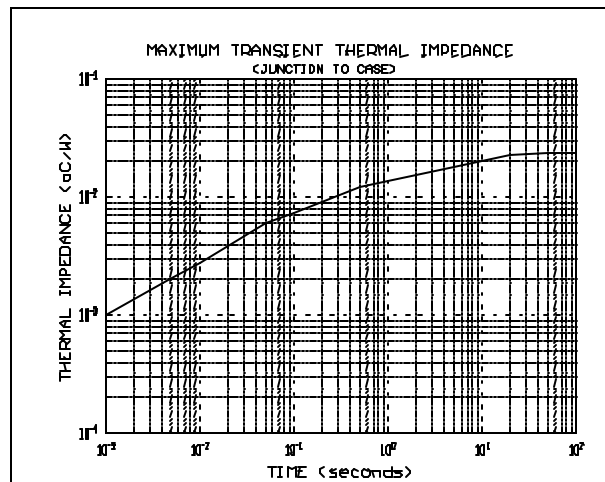
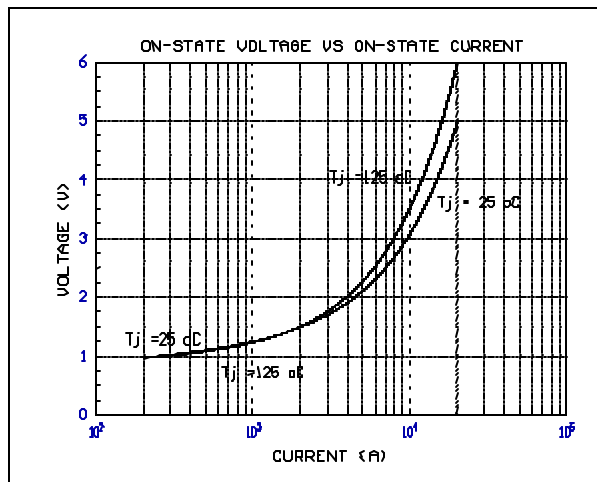

TN450CH series Power Thyristor

Page 4 of 4

CASE OUTLINE AND DIMENSIONS.

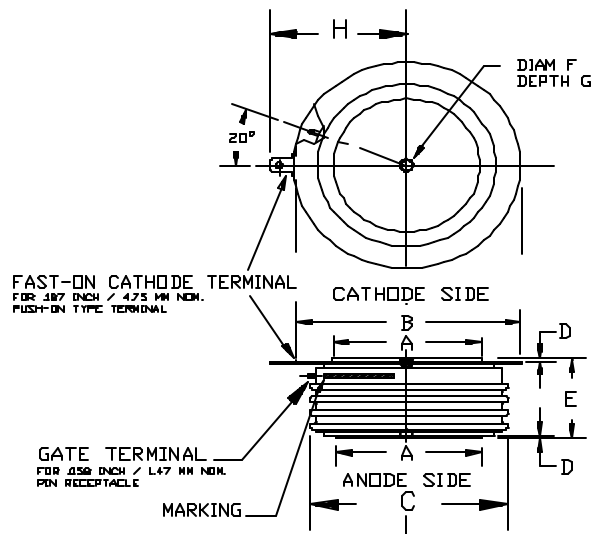

STRIKE DISTANCE = .58 INCH / 14.7 MM MIN.
GREENPADE DISTANCE = .610 INCH / 15.4 MM MIN.

OUTLINE DIMENSIONS - CASE 4T				
DIMENSIONS	Min. mm	Max. mm	Min. In.	Max. In.
DIAM A	43.18	46.26	1.70	1.90
DIAM B	63.50	75.18	2.50	2.96
DIAM C	--	67.31	--	2.65
D	0.76	--	0.03	--
E	25.40	27.18	1.00	1.07
F	3.30	3.81	0.13	0.15
G	1.78	2.03	0.07	0.08
H	--	44.20	--	1.74