



Semitronics Corp., 64 Commercial St. Freeport, NY 11520 Tel. (516) 623-9400 FAX (516) 623-6954

Power Thyristor 1840 Amps – 6500 Volts TN880CH series

Features:

- . All Diffused Structure
- . Linear Amplifying Gate Configuration
- . Blocking capability up to 6500 volts
- . Guaranteed Maximum Turn-Off Time
- . High dV/dt Capability
- . Pressure Assembled Device

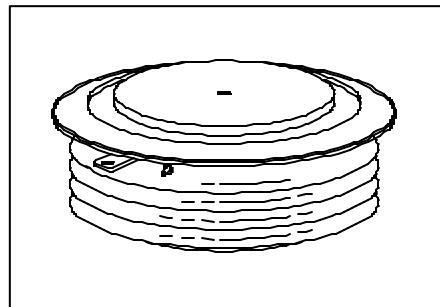

ELECTRICAL CHARACTERISTICS AND RATINGS

Blocking - Off State

Device Type	V _{RRM} (1)	V _{DRM} (1)	V _{RSM} (1)
TN880CH60	6000	6000	6000
TN880CH62	6200	6200	6200
TN880CH64	6400	6400	6400
TN880CH65	6500	6500	6500

V_{RRM} = Repetitive peak reverse voltage

V_{DRM} = Repetitive peak off state voltage

V_{RSM} = Non repetitive peak reverse voltage (2)

Repetitive peak reverse leakage and off state leakage	I _{RRM} / I _{DRM}	40 mA 600 mA (3)
Critical rate of voltage rise	dV/dt (4)	2000V/μsec

Notes:

All ratings are specified for T_j=25 °C unless otherwise stated.

- (1) All voltage ratings are specified for an applied 50Hz/60Hz sinusoidal waveform over the temperature range -40 to +125 °C.
- (2) 10 msec. max. pulse width
- (3) Maximum value for T_j = 125 °C.
- (4) Minimum value for linear and exponential waveshape to 80% rated V_{DRM}. Gate open. T_j = 125 °C.
- (5) Non-repetitive value.
- (6) The value of di/dt is established in accordance with EIA/NIMA Standard RS-397, Section 5-2-2-6. The value defined would be in addition to that obtained from a snubber circuit, comprising a 0.2 μF capacitor and 20 ohms resistor in parallel with the thyristor under test.

Conducting - on state

Parameter	Symbol	Min.	Max.	Typ.	Units	Conditions
Average value of on-state current	I _{T(AV)}		1170		A	Sinewave, 180° conduction, T _c =70°C
RMS value of on-state current	I _{TRMS}		1840		A	Nominal value
Peak one cycle surge (non repetitive) current	I _{TSM}		18700		A	10.0 msec (50Hz), sinusoidal waveshape, 180° conduction, T _j = 125 °C
I square t	I ² t		1.75x10 ⁶		A ² s	8.3 msec and 10.0 msec
Latching current	I _L		1000		mA	V _D = 24 V; R _L = 12 ohms
Holding current	I _H		200		mA	V _D = 24 V; I = 2.5 A
Peak on-state voltage	V _{TM}		3.3		V	I _{TM} = 3000 A; T _j = 125 °C
Critical rate of rise of on-state current (5, 6)	di/dt		300		A/μs	Switching from V _{DRM} ≤ 2000 V, non-repetitive
Critical rate of rise of on-state current (6)	di/dt		100		A/μs	Switching from V _{DRM} ≤ 2000 V

ELECTRICAL CHARACTERISTICS AND RATINGS (cont'd)

Gating

Parameter	Symbol	Min.	Max.	Typ.	Units	Conditions
Peak gate power dissipation	P_{GM}		16		W	$t_p = 40 \mu s$
Average gate power dissipation	$P_{G(AV)}$		5		W	
Peak gate current	I_{GM}		20		A	
Gate current required to trigger all units	I_{GT}		300 200 125		mA mA mA	$V_D = 6 V; R_L = 3 \text{ ohms}; T_j = -40^\circ C$ $V_D = 6 V; R_L = 3 \text{ ohms}; T_j = +25^\circ C$ $V_D = 6 V; R_L = 3 \text{ ohms}; T_j = +125^\circ C$
Gate voltage required to trigger all units	V_{GT}	0.30	5 4		V V V	$V_D = 6 V; R_L = 3 \text{ ohms}; T_j = -40^\circ C$ $V_D = 6 V; R_L = 3 \text{ ohms}; T_j = 0-125^\circ C$ $V_D = \text{Rated } V_{DRM}; R_L = 1000 \text{ ohms}; T_j = +125^\circ C$
Peak negative voltage	V_{GRM}		20		V	

Dynamic

Parameter	Symbol	Min.	Max.	Typ.	Units	Conditions
Delay time	t_d		3.0	2.5	μs	$I_{TM} = 50 A; V_D = 2000 V$ Gate pulse: $V_G = 20 V; R_G = 20 \text{ ohms}; t_r = 0.1 \mu s; t_p = 20 \mu s$
Turn-off time (with $V_R = -50 V$)	t_q		400	250	μs	$I_{TM} > 2000 A; di/dt = 10 A/\mu s;$ $V_R \geq -50 V; \text{Re-applied } dV/dt = 500 V/\mu s \text{ linear to } 2000 V; V_G = 0;$ $T_j = 125^\circ C; \text{Duty cycle } \geq 0.01\%$
Reverse recovery current	I_{rr}		140		A	$I_{TM} > 2000 A; di/dt = 10 A/\mu s;$ $V_R \geq -50 V$

THERMAL AND MECHANICAL CHARACTERISTICS AND RATINGS

Parameter	Symbol	Min.	Max.	Typ.	Units	Conditions
Operating temperature	T_j	-40	+125		$^\circ C$	
Storage temperature	T_{stg}	-40	+150		$^\circ C$	
Thermal resistance - junction to case	$R_{\Theta(j-c)}$		0.012		$^\circ C/W$	Double sided cooled Single sided cooled
Thermal resistance - case to sink	$R_{\Theta(c-s)}$		0.002		$^\circ C/W$	Double sided cooled * Single sided cooled *
Mounting force	P	8000 35.5	10000 44.4		lb. kN	
Weight	W			3.5 1.60	Lb. Kg.	

- Mounting surfaces smooth, flat and greased

CASE OUTLINE AND DIMENSIONS.

